

Installing the LYNXR-2 Series Control

This Quick Start Guide can help you install the rechargeable LYNXR-2 Series Control quickly and easily by providing the basic steps for installation using the built-in defaults. Lynxr-2 also features a Voice Prompt Programming mode that allows you to program the system by responding to a series of voice prompts. For more detailed information and important notes, refer to the LYNXR-2 Series Installation and Setup Guide.

Step 1 - Install the Control

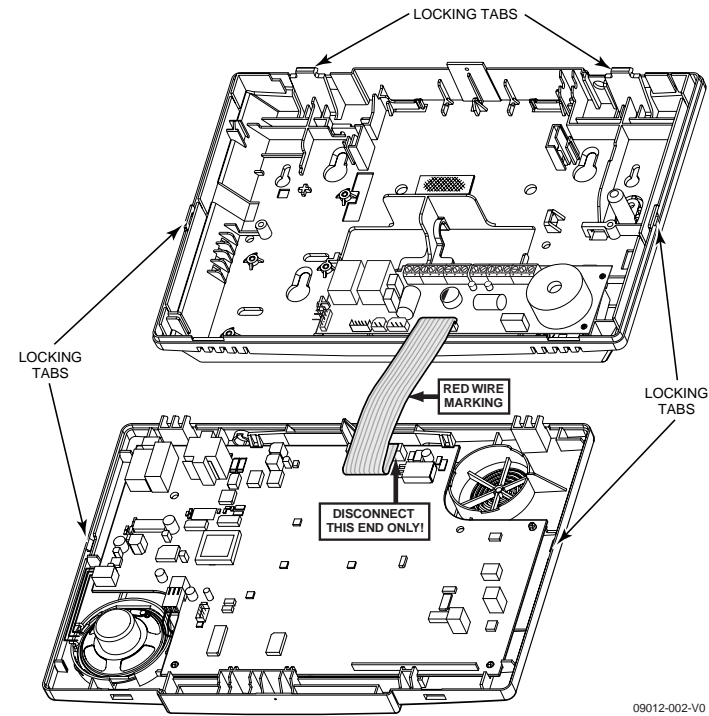

09012-002-V0

1. Separate the front assembly from the back plate and disconnect the cable from the front assembly board.
Note: Disconnect the cable only from the front assembly board, not from the terminal block PC board.
2. Mount the back plate to a sturdy wall.
3. After wiring connections are made, carefully reconnect the ribbon cable and snap the front assembly to the back plate.

Step 2 - Make Wiring Connections

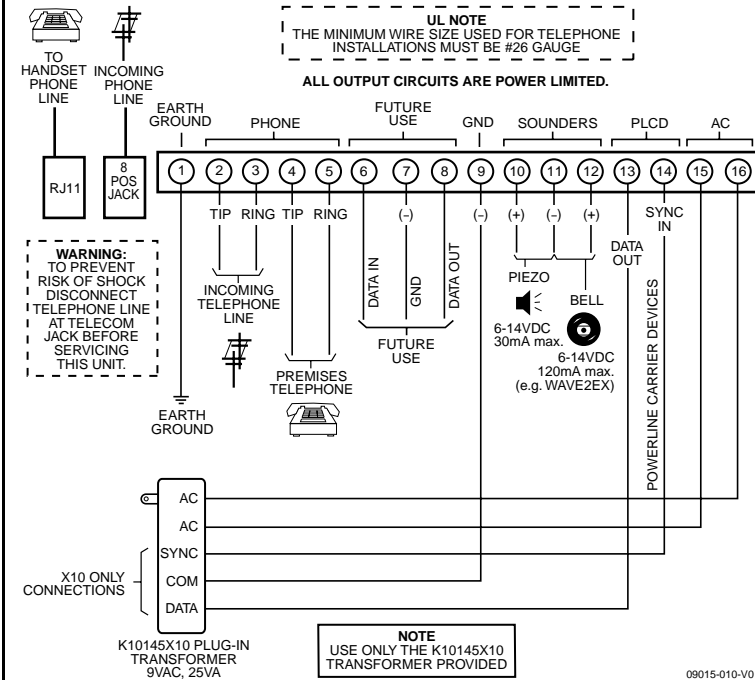

09015-010-V0

Note: For the complete Summary of Connections, refer to the LYNXR-2 Series Installation and Setup Guide

1. Connect the incoming phone line to either the 8-position jack or terminals 2 (TIP) and 3 (RING).
2. Connect the handset phone lines to either the RJ11 jack or terminals 4 (TIP) and 5 (RING).
Note: For full line seize operation, refer to the LYNXR-2 Series Installation and Setup Guide.
3. If used, connect a piezo sounder to terminals 10 (+) and 11 (-).
4. If used, connect a bell to terminals 11 (-) and 12 (+).
5. If using Powerline Carrier Devices, connect com/data/sync/ lines from the K10145X10 transformer to terminals 9, 13, and 14 respectively.
6. If used, connect the IP or GSM communications device to the AlarmNet LRR/IP communications port.
Note: Install Powerline Carrier Devices according to their instructions.
7. Connect wires from the K10145X10 (K10145CN) AC Transformer to terminals 15 and 16.

Step 3 - Make Battery Connections

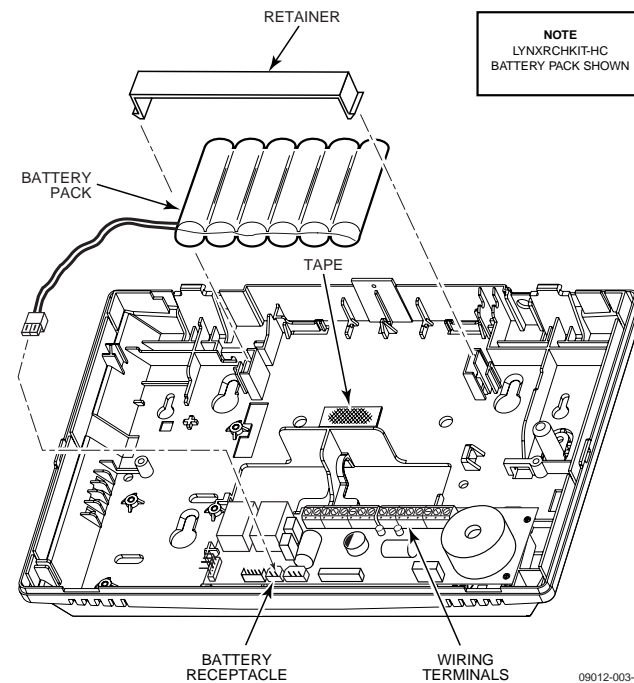

09012-003-V0

1. Remove battery retainer.
2. Remove backing from tape on back plate.
3. Insert battery pack into back plate.
4. Install battery retainer.
5. Connect battery connector to receptacle on terminal block PC board.
6. Carefully reconnect the ribbon cable to the front assembly PC board connector (properly aligning the red wire).
7. After all wiring connections have been made, snap the front assembly to the back plate so it is held by the locking tabs.
8. Plug the transformer into a 24-hour, 110VAC unswitched outlet.
Note: Rechargeable batteries may take up to 48-hours to fully charge. "LOW BAT" message should clear within four hours, or by entering Test Mode.

Step 4 - Program the Control

Change the Installer Code

The factory default Installer Code for the LYNXR-2 Series Control is set to 4-1-1-2. To change this code, you must enter Expert Programming mode.

1. After Power-up, enter Installer Code + 8 0 0 or press both the [*] and [#] simultaneously within 50 seconds after power is applied to the control. The system will enter the Expert Programming Mode and "20" will be displayed.

Note: Upon power-up or after exiting program mode, the system takes up to a minute to reset. To bypass the reset delay, enter [#] + [0].

2. Enter *20
3. Enter a new four-digit Installer Code.

Program variable data fields

1. If required, enter *24 to program the desired 2-digit RF House ID for wireless keypads.
2. If required, enter *40 to program a PABX Access Code or to Disable Call Waiting (LYNXR-2SIA only)
3. Enter *94 to program the downloading computer phone number.
4. Press the ESCAPE/[OFF] key to enter Voice Prompt Program mode. The system will announce, "Programming, use ARROWS to scroll choices, press SELECT to accept, press ESCAPE to quit." The system will announce the available options.



The FUNCTION/[#] key can be used to repeat a voice prompt, as required.

5. Follow the directions provided by each voice prompt to make your selections.
6. When you have completed each programming procedure the system will return to the Main Programming Menu.

Step 5 – Voice Prompt Programming

Navigating the Voice Prompt Programming Mode

Scroll through the voice menu and follow the instructions provided to continue using the Voice Prompt Programming Mode.

The following keys are used to navigate through this feature.

- ESCAPE/ [OFF]** key: Used at any time to exit the current menu and return to the previous prompt.
- ADD/ [AWAY]** key: Used to add sensors or keys or save data when entering phone or account numbers.
- DELETE/ [STAY]** key: Used to delete a sensor when in the delete Sensors Menu.
- SELECT/ [AUX]** key: Used to confirm a selection.
- [3 ↑]** key: Used to scroll forward through menu choices.
- [6 ↓]** key: Used to scroll backward through menu choices.
- FUNCTION/ [#]** key: Used to repeat a voice prompt. (This function cannot be used while entering phone or account numbers.)

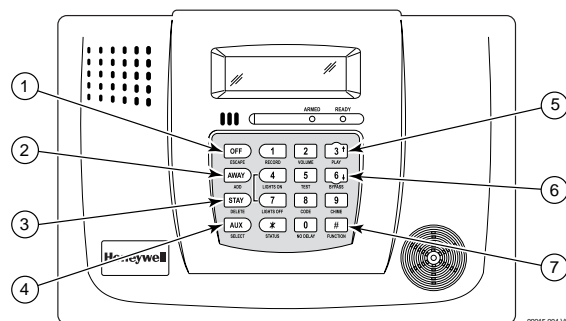

Step 6a – Add Sensors

The LYNXR-2 Series will enroll a sensor once the transmitter has been activated two times. The system will confirm the enrollment following each subsequent activation of the same transmitter.

Add a Door Sensor

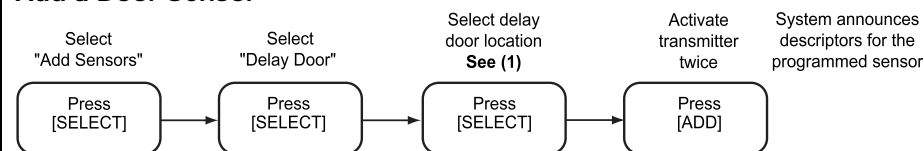

(1) Delay Door Location

Front Back Side Garage Basement
Sliding Hall Kitchen Patio

Add a Window, Motion Detector, Or Fire Detection Sensor

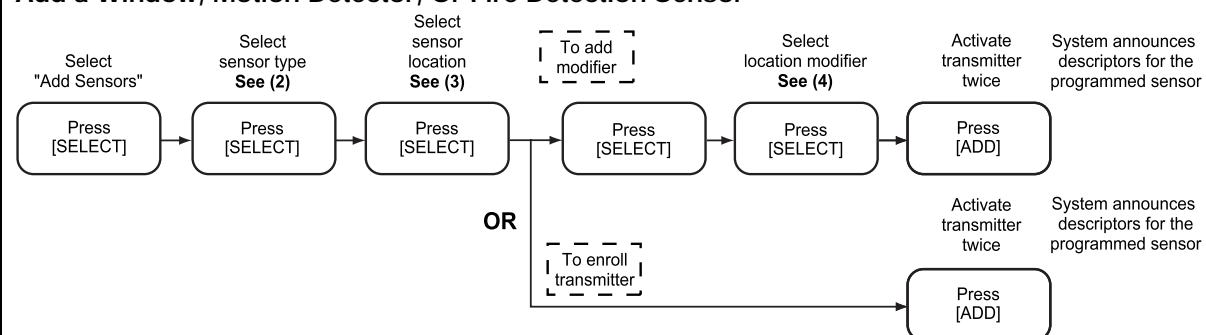

(2) Sensor Type

Window
Motion Detector
Fire Detection

(3) Sensor Location

Living room Kitchen Family Room Attic
Dining room Hall Guest Room Office
Bedroom Basement Laundry Room Upstairs
Bathroom Master Bedroom Utility Room
Nursery Den Garage

(4) Location Modifiers

Upstairs Second Floor
Downstairs Front
First Rear
Second Side
Third

Step 6a – Add Sensors (Continued)

Add an Emergency Pendant

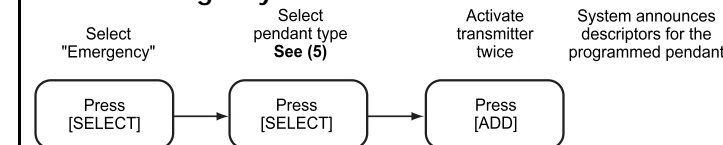

(5) Pendant Type

Medical Fire Silent Police Police

Add a Wireless Key

When adding wireless keys, wait 5 seconds between transmissions.

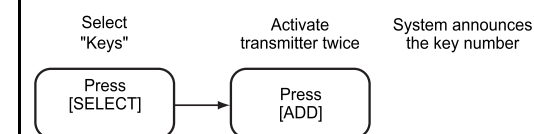

Step 6b – Delete Sensors

Delete Sensors

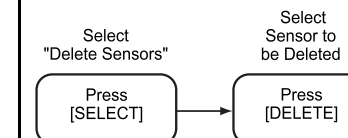

Step 7 – Add Central Station Accounts

Add First Central Station Phone Number

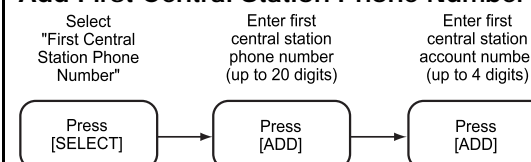

Add First Central Station Account Number

All four digits of the Central Station Account numbers must be entered. For ten-digit format, all ten digits must be entered. Refer to the LYNXR-2 Series Installation and Setup Guide for additional information regarding these programming options.

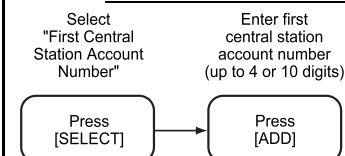

Add Second Central Station Phone Number

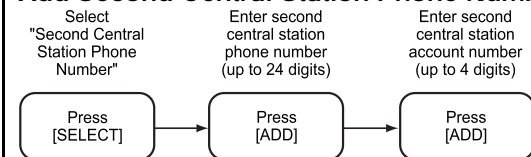

Add Second Central Station Account Number

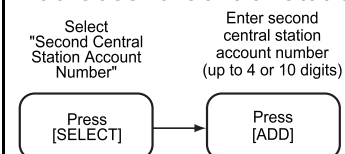

Step 8 – Program Additional Options

Enter Expert Programming Mode

Once you have entered the Expert Programming Mode, the [ESCAPE] key can be used to return to the Voice Prompt Programming mode. If you are in any of the Interactive Menu Modes (*56, *80, *81, *83, *84 or *85), you must return to the main menu in that field before pressing the [ESCAPE] key.

The LYNXR-2 Series is configured with Factory Default Settings. You can revise these settings using the Expert Programming Mode. Refer to the Installation and Setup Guide to view these defaults and to continue programming the individual fields using this mode.

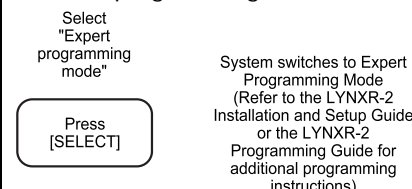

Exit Expert Programming Mode

When programming is complete, enter *99.

Step 9 – Perform Go/No Go Test

Temporarily mount wireless devices in the preferred mounting location and perform a Go/No Go test to ensure adequate signal strength is available.

- Enter Installer Code + [#] + [8] and run Go/No Go Test.
- Fault each transmitter to ensure all programmed zones are received.
- Mount the transmitter in its permanent location.

Step 10 – Program User Functions

Set the Real-Time Clock

- Enter the Installer Code + FUNCTION/ [#] + 63
- Follow the Voice Prompts to program the Clock/Calendar.

Change the Master User Code

- Enter the Installer Code + CODE/ [8] + 02 + desired 4-digit Master Code.

Add User Codes

- By following the procedures in the LYNXR-2 Series User Guide, show the User how to add additional User Codes.

Step 11 – Test the system

- Enter the User Code + [TEST] key. The external sounder will sound for two seconds and all the LCD segments on the keypad display light for 3 seconds.
- Open each protected door and listen for three beeps from the keypad, followed by the zone's Voice Descriptor. Identification of each faulted protection point should appear on the display, and clear when the door is closed.
- Walk in front of the motion sensor and listen for three beeps and the zone's voice descriptor.
- When testing is complete, enter: User Code + [OFF] key.
- Press each key on the key fob to confirm it performs its assigned function.

Note: Refer to the LYNXR-2 Series User Guide for additional information.

Programming Notes

Entering Voice Prompt Programming

Power-up the control and enter the Installer Code + 8 8 8. When you have completed each programming procedure the system will return to the Main Programming Menu.

Exiting Voice Prompt Programming

Once you have returned to the Main Programming Menu, press the ESCAPE/ [OFF] key.

Entering Central Station Phone Numbers

Enter 0-9, # + 11 = *, # + 12 = #, # + 13 = a pause of 2 seconds.

Entering Central Station Account Numbers

Enter 0-9, # + 11 = B, # + 12 = C, # + 13 = D, # + 14 = E, # + 15 = F

Programming Zone Types

The Voice Prompt Programming feature can not be used to program Zone Types 02, 05, 10, 14, 16 (LYNXR-2SIA) and 24. Programming these zone types must be done using the Expert Programming Mode.

